Execution:

similar DIN 1587

produced by machining or forging

Material:

 1.1181 acc. DIN EN 10269 and AD2000: W7/1
 1.4301 acc. DIN EN 10088-3 and AD2000: W7/2
 1.7218 acc. DIN EN 10269 and AD2000: W7/1
 Gr. 2H nach ASME Sec. II, Part A; SA-194
 Gr. 8 nach ASME Sec. II, Part A; SA-194
 with inspection certificate acc. to
 DIN EN 10204 - 3.1

Note:

The clamping length of our screwclamps decreases.

Thread:

ISO - DIN 13, tolerance 6 H

Unspecified dimensions acc. DIN 1587

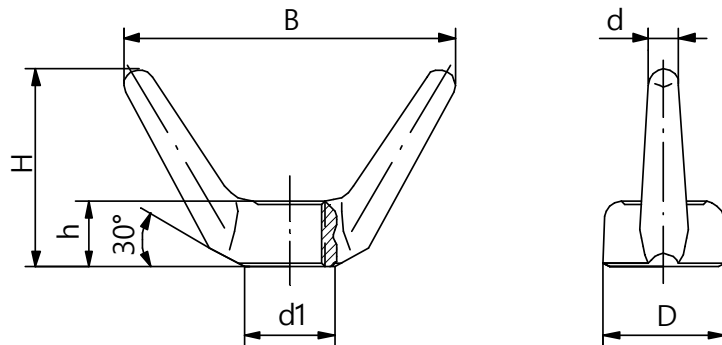
Execution:

 Drop forged, without cracks and wrinkles
 surface sandblasted

Material:

 1.4541 acc. DIN EN 10222-5 and AD2000: W7/2
 Gr. 8T acc. ASME SA-194, Sec. II, Part A
 with inspection certificate acc. to
 DIN EN 10204 - 3.1

Thread:

ISO - DIN 13, tolerance 6 H

 Dimensional variation of the external shape
 permitted acc. DIN EN 10243

	Thread	d3	e	f	t	m	s	w	h	B	H	D	d1	d	Weight kg/%	
Cap-nut	M10	16	18	12	26	10	17	2	31						3,7	
	M12	18	22	15	32	12	19	3	38						5,0	
	M16	22	28	20	38	14	24	3	45						7,5	
	M20	28	34	22	44	18	30	3	52						14,8	
	M24	34	42	25	53	23	36	3	60						25,4	
	M27	38	47	29	59	25	41	4	68						35,0	
	M30	45	53	36	70	28	46	5	80						54,0	
	M33	48	57	41	79	30	50	5	89						70,0	
	M56x2	70	96	54	114	56	85	5	140						267,5	
Wing nuts	M10									13	62	39	24	17	6	7,1
	M12									15	81	53	26	19	8	12,0
	M16									20	112	77	35	24	10	27,8
	M20									25	150	95	40	30	10	48,3
	M24									30	170	113	45	36	12	65,2